

Wiring diagram for 3 wire motor Mako 1500 - 2000

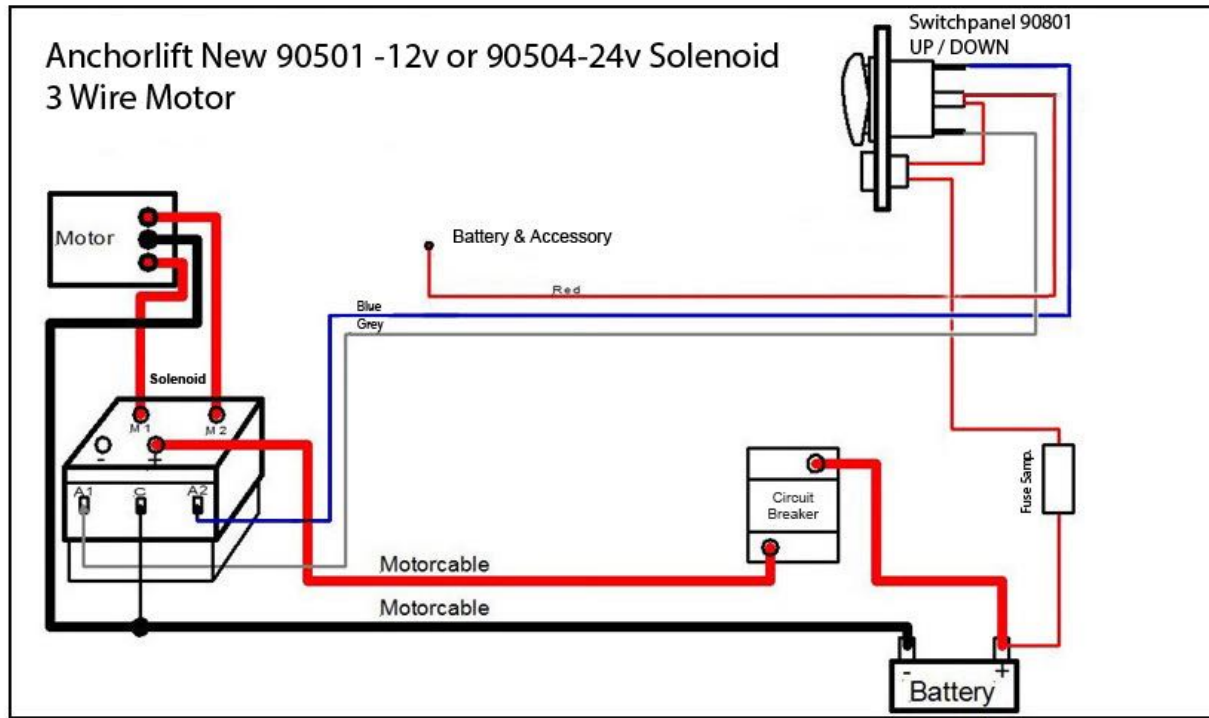

Wiring diagram for 4 wire motor Aquarius 2500 - 3000

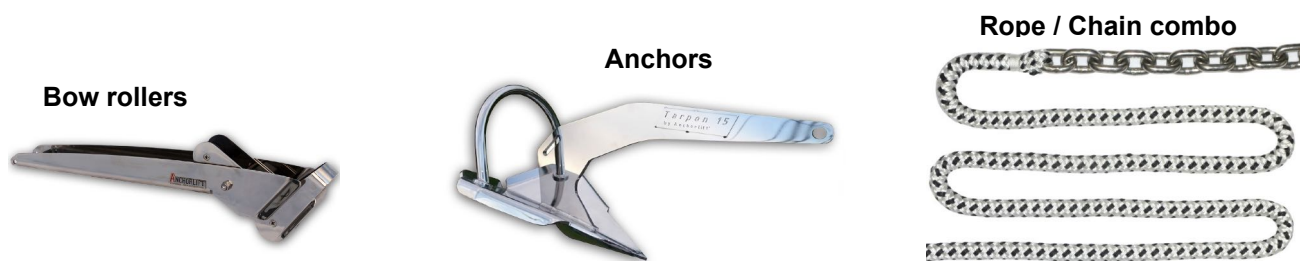
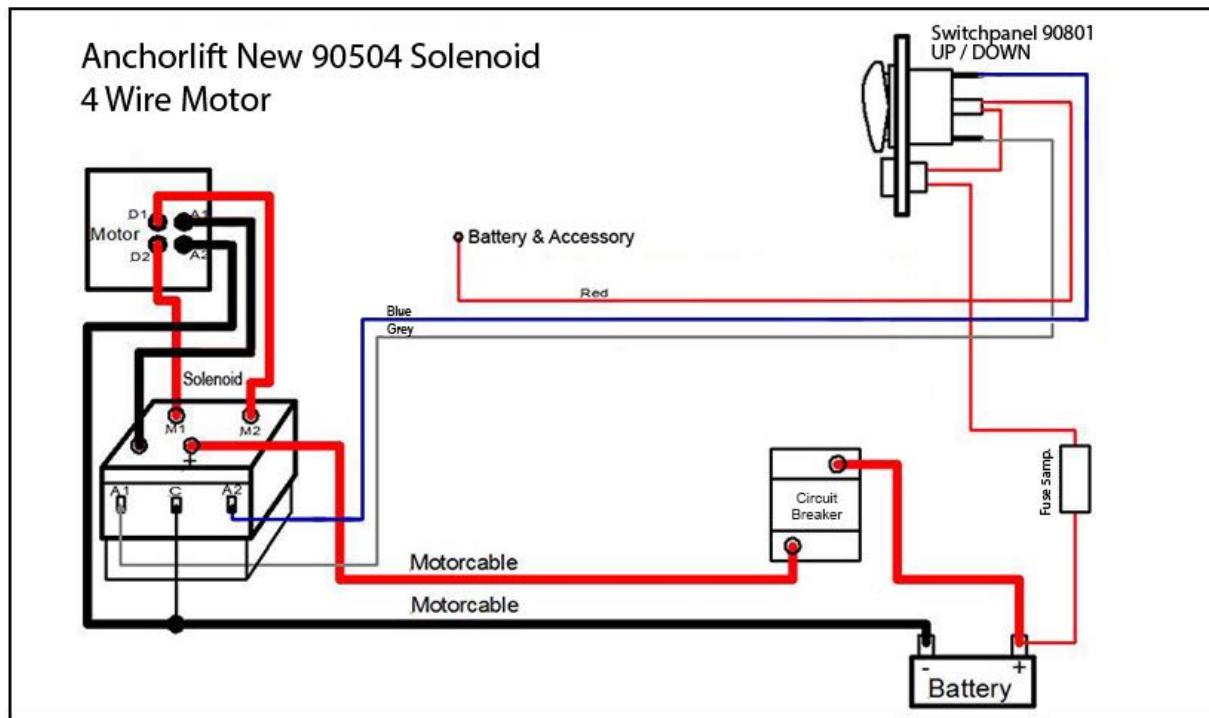

# Installation Quick Guide

Read Quick Guide carefully before starting installation!

Visit [www.anchorliftdirect.com](http://www.anchorliftdirect.com) "Customer Support" for the full version of User Manual

Make sure to position the windlass so that the center line of the chain / rope aligns with the bow roller in a horizontal plane, and that the vertical line is within 10 degrees (See photo P 3) of the rope / chain gypsy.

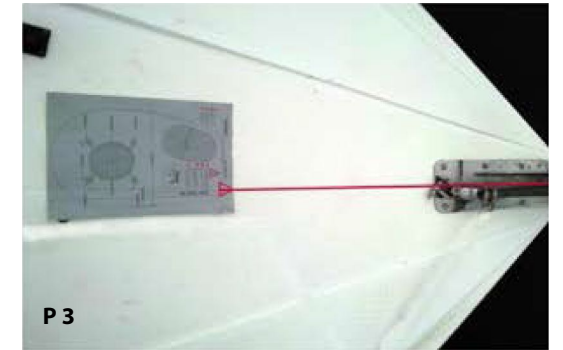

Drill and cut out holes to the size detailed on the template. Make sure that the chain pipe hole is angled and smooth to allow the chain / rope / rode kit to easily pass through it (See drawing P 4). Note: With a sandwiched deck construction, it is important to seal the exposed surface.

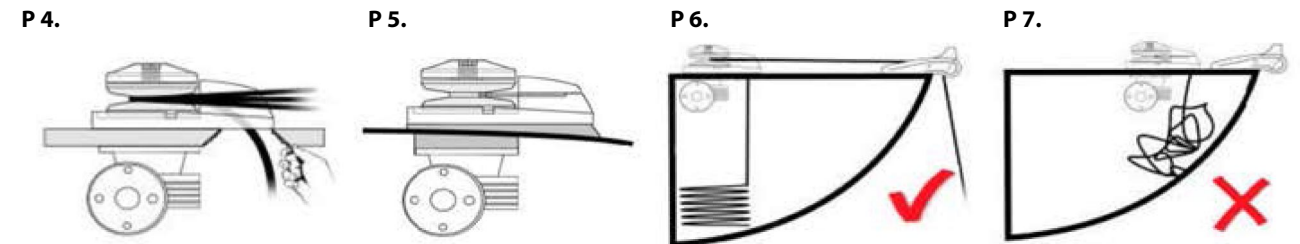

**NOTE:** Care should be taken when installing the windlass to ensure that the vertical drop below the chain pipe exit is maximized. Remember that rope coils unlike chain, and will require as much anchor locker space as possible (See drawings P 6 and P 7).

The Gear Box is fitted with a removable mounting flange that can be mounted on both sides of the gear box. It's important that the motor is mounted as far away from the chain pipe hole as possible. See illustrations below: Photos of motor gear box installations

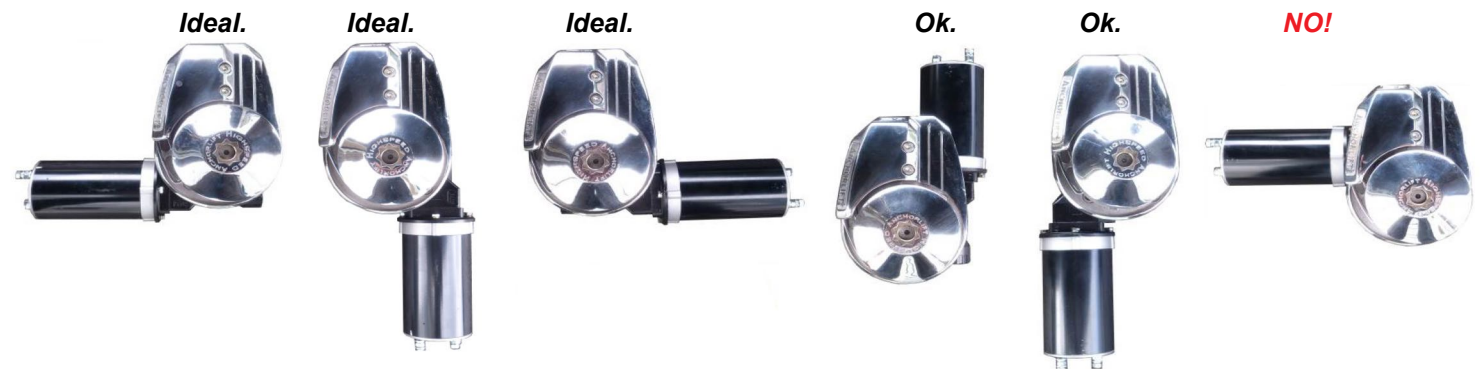

## Getting Started:

Check the contents of the box. The standard package consists of: Windlass deck unit, Gear Box/Motor unit, Solenoid, Clutch Handle, Mounting Hardware, Drilling Template and Quick Install Guide.



Recommended on all installations: Helm Switch, Foot Switches, Circuit Breaker, Anchor Safety Strap

90801



90900B



90080-175



91406



## Assembly

The windlass is to be placed in position by aligning the gypsy with the bow point (rope or chain level with the deck and wound around the gypsy at an angle of about 180 degrees)

Before drilling holes, check the following: There are to be no obstacles below deck in order to install the bottom part.

There must be enough space for the Chain - Rope / Chain Rode Kit.

Make sure the top and bottom surfaces of the deck are as parallel as possible.

If necessary, compensate for any differences to prevent base & gearbox (see picture **P.5**) from being damaged. Once the ideal position has been found, drill the holes using the Mounting Template. Place the top part (base) in position and connect it to the bottom part (gearbox / motor). Fit the shaft into the gearbox.

**MAKE SURE THE SHAFT AND GEAR BOX BUSHING IS WELL GREASED!!** (See Step #1)

before connecting to the gearbox. See the wiring diagram for the electrical installation for your windlass.

### Tools Required:

Pencil  
Drill  
Drill Bit  
Hole Saw  
Rasp / File  
Metric wrench set  
Metric Allen wrench set  
Pliers  
Wire Snips/Crimps

### Deck Thickness:

**Barracuda:** 20 - 40mm, 3/4" - 1 1/2"

**Dolphin:** 25 - 50mm, 1" - 2"

**Mako:** 25mm to 65mm, 1" - 2.5"

**Aquarius:** up to 190mm / 7.5"

**Note:** For deck thickness greater than the maximum measures mentioned here please contact Anchorlift Customer Support for available options.

### Supplies Needed:

Masking Tape  
Marine Grease (Blue waterproof)  
Thread locker (Red Loc-Tite® or similar)

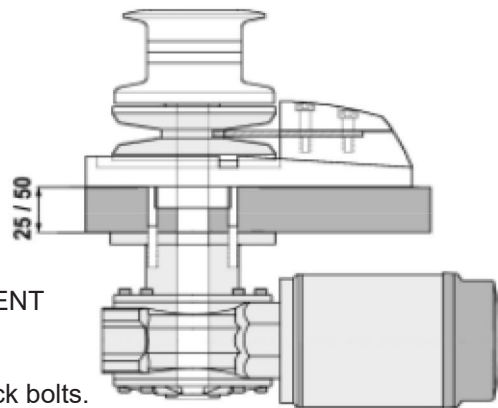

EPDM GASKET FOR SEAMLESS ATTACHMENT TO DECK SURFACE.

Use threadlocker on deck bolts.

Grease shaft well with marine grease.

**! Improper installation will result in void in warranty**

## STEP 1

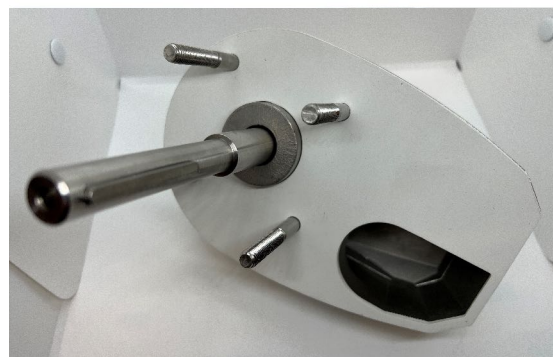

## STEP 2



Before mounting gear box/motor unit:  
Spray flange well with anti-corrosion spray.  
Use Corrosion X or CRC Heavy Duty Corrosion Inhibitor anti-corrosion products.

Motor can be mounted 5 different ways:  
We recommend mounting the motor pointing to the starboard side, then the motor will be as far away from the rope and chain as possible.

**! Improper installation will result in void in warranty**

## STEP 3



After mounting the gear motor unit, and performing function test.  
Spray the complete under deck unit well with anti corrosion spray.  
This is important to get a trouble free operation for years to come.  
The wet environment in the anchor locker is extreme and over time will damage the gearbox and motor!

Use Corrosion X or CRC Heavy Duty Corrosion Inhibitor anti-corrosion products.

**! Improper installation will result in void in warranty**

## Chain and Rope Size:

Model:	Gypsy:	Rope:
Barracuda	1/4"	1/2"
Dolphin	5/16"	5/8"
Mako	5/16" + 3/8"	5/8"
Aquarius	ISO 3/8" + 1/2"	N/A

## Chain: USA and Canada Standard

Model	Size	Weight ft	Dimensions Inside	Breaking load	Windlass Model
HT1/4"	1/4"	0.74 lbs	0.845 x 0.41"	6700 lbs	Barracuda
HT5/16"	5/16"	1.03 lbs	1.03 x 0.51"	8900 lbs	Dolphin Mako
HT3/8"	3/8"	1.48 lbs	1.22 x 0.59"	13500 lbs	Mako Aquarius
HT1/2"	1/2"	2.57 lbs	1.59 x 0.76"	25000 lbs	Aquarius

## Cable sizes

We recommend the use of the following cables, switch-wiring and circuit breaker sizes:

Windlass	Cable length: 0-8m 0-24ft		over 8m 24ft		Circuit Breaker
Barracuda 600	16mm2	4-6AWG	25mm2	4AWG	80amp (90080)
Barracuda 900	25mm2	4AWG	35mm2	4AWG	100amp (90100)
Dolphin 1000	25mm2	4AWG	35mm2	2AWG	100amp (90100)
Mako 1500 12v	35mm2	2AWG	50mm2	2AWG	135amp (90135)
Mako 1500 24v	25mm2	2AWG	35mm2	2AWG	80-100amp (90080-90100)
Aquarius 2500 24v	35mm2	2AWG	50mm2	0AWG	135amp (90135)
Aquarius 3000 24v	35-50mm2	2-0AWG	50mm2	0AWG	175amp (90175)

**! Solenoid should be mounted in a dry place.  
Do not mount the solenoid inside the anchor locker!  
Switch off all electric before working on electric cables!**

**! Recommend spraying all electrical components with anti-corrosion spray.  
WD40, CRC565, or similar products.**

## Electrical Installation:

### Wiring diagram for 2 wire motor Barracuda 600-900 and Dolphin 1000

